



# User Manual



## ULTRAVOICE XM1800S

3 Dynamic Cardioid Vocal and Instrument Microphones (Set of 3)



EN

## 1. Introduction

Thank you for expressing your confidence in us by purchasing the BEHRINGER XM1800S dynamic microphone. The XM1800S combines highest quality standards at an affordable price and best results in audio performances for both vocal and instrument miking applications. The features of the XM1800S will make it a valuable tool for your recording and live performance.

## 2. Audio Connection

Use a standard microphone cable to connect your XM1800S to any mixer, power mixer, amp, or mic preamp. Connect the female XLR end to the XM1800S' male XLR input connector and the other end of the cable, normally a male XLR connector, to the mixer, power mixer, amp, or mic preamp.

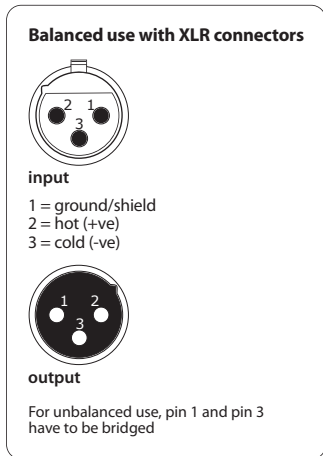

Fig. 2.1: Balanced XLR connector

## 3. How to Use your XM1800S Most Effectively

Adjust the gain control in the microphone channel of your mixing console so that the peak LED lights up only occasionally or never at all. The EQ controls in the microphone channel should be set to mid-travel position to start with; low-cut filter and level attenuator should be turned off. Try to achieve the desired sound by experimenting with the microphone position. Place the microphone as close to the sound source as possible. The closer your mic gets to the sound source, the greater the bass response will be. On the other hand, as you move the sound source further away from the microphone, the bass response will gradually roll off (please see frequency response chart on next page).

Only when the desired basic sound has been achieved, should you start to use equalizers and signal processors, if any at all. (Remember: less is often more!)

All microphones have characteristic polar patterns that determine how well signals from around the area of the microphone are accepted or rejected.

The super cardioid pattern is used by the XM1800S. Thus, the XM1800S excels in environments where a lot of undesired ambient noise exists. The XM1800S excellently reproduces those sound signals originated directly in front of the microphone while rejecting or minimizing sound signals originated in the area behind the microphone (please refer to the polar pattern on next page for detailed information).

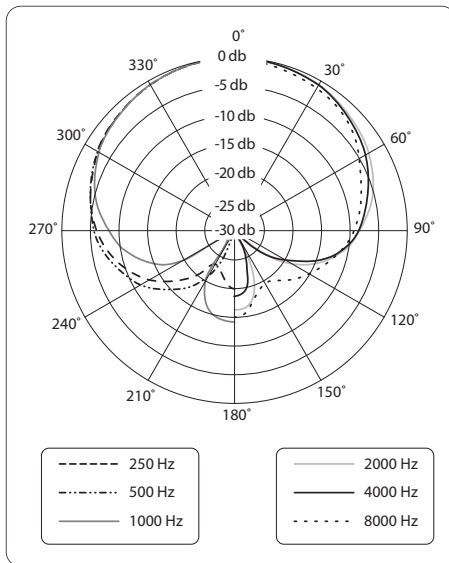

Polar diagram

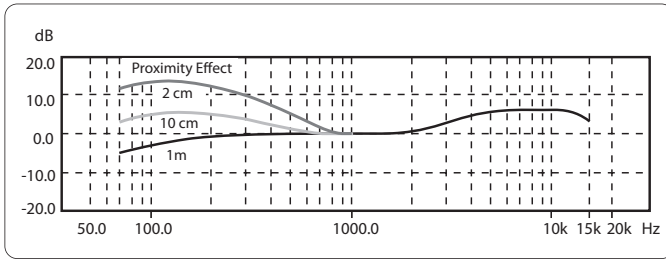

frequency response chart

## 4. Specifications

Type	Dynamic
Frequency response	80 Hz - 15 kHz
Polar pattern	Super cardioid
Impedance	600 $\Omega$
Sensitivity	-52 dBV (0 dBV = 1 V/Pa), 2.5 mV/Pa
Connector	3-pin balanced XLR (male)

### Physical/Weight

#### Dimensions

Head length	57.5 mm
Main unit length	117.5 mm
Total length	175 mm
Weight	270 g

MUSIC Group accepts no liability for any loss which may be suffered by any person who relies either wholly or in part upon any description, photograph, or statement contained herein. Technical specifications, appearances and other information are subject to change without notice. All trademarks are the property of their respective owners. MIDAS, KLARK TEKNIK, LAB GRUPPEN, LAKE, TANNOY, TURBOSOUND, TC ELECTRONIC, TC HELICON, BEHRINGER, BUGERA and DDA are trademarks or registered trademarks of MUSIC Group IP Ltd. © MUSIC Group IP Ltd. 2016 All rights reserved.

Dedicate Your Life to Music